

S.O. 23097

Report of Test 6810-4-H/V-DA

for

RADIO MARIA, INC.

KOJO 91.1 MHz LAKE CHARLES, LA

OBJECTIVE:

The objective of this test was to demonstrate the directional characteristics of a 6810-4-H/V-DA to meet the needs of KOJO and to comply with the requirements of the FCC construction permit, file number BMPED-20021028AAB.

RESULTS:

The measured azimuth pattern for the 6810-4-H/V-DA is shown in Figure 1. Figure 1A shows the Tabulation of the Vertical Polarization. The horizontal azimuth pattern of this antenna is omni-directional and therefore is not shown. The calculated elevation pattern of the antenna is shown in Figures 3 and 3A. Construction permit file number BMPED-20021028AAB indicates that the Vertical radiation component shall not exceed 14.0 kW at any azimuth and is restricted to the following values at the azimuths specified:

80 clockwise to 100 Degrees T: 8.96 kW

270 Degrees T: 9.18 kW

From Figure 1, the maximum radiation of the Vertical component occurs at 345 Degrees T to 359 Degrees T. At the restricted azimuth of 80 to 100 Degrees T the Vertical component is 2.16 dB down from the maximum of 14.0 kW, or 8.51 kW. At the restricted azimuth of 270 Degrees T the Vertical component is 2.21 dB down from the maximum of 14.0 kW, or 8.42 kW.

The R.M.S. of the Vertical component is 0.720. The total Vertical power gain is 5.270. See Figure 4 for calculations.

AMENDED FCC COMPOSITE PATTERN:

The R.M.S. of the measured pattern is 0.720. Eighty-five percent (85%) of the original authorized FCC composite pattern is 0.816. Therefore the measured pattern does not comply with the FCC requirement of 73.316(c)(ix)(A). In accordance with 73.1690(c)(2)(ii), an amended composite pattern is attached as Figure 5 that will allow the above measured pattern to comply with the FCC requirement of 73.316(c)(ix)(A). Figure 5a shows the tabulations of the amended composite Figure 5. Eighty five percent (85%) of the amended FCC composite pattern is 0.719. Therefore the RMS of the measured pattern will comply with the requirement of 73.316(c)(ix)(A).

METHOD OF DIRECTIONALIZATION:

One bay of the 6810-4-H/V-DA was mounted on a tower of exact scale to a LaRouge 36" face tower. The spacing of the antenna to the tower was varied to achieve the vertical pattern shown in Figure 1. See Figure 2 for mechanical details.

METHOD OF MEASUREMENT:

As allowed by the construction permit, file number BMPED-20021028AAB, a single level of the 6810-4-H/V-DA was set up on the Howell Laboratories scale model antenna pattern measuring range. A scale of 4.5:1 was used.

SUPERVISION:

Mr. Surette was graduated from Lowell Technological Institute, Lowell, Massachusetts in 1973 with the degree of Bachelor of Science in Electrical Engineering. He has been directly involved with design and development of broadcast antennas, filter systems and RF transmission components since 1974, as an RF Engineer for six years with the original Shively Labs in Raymond, ME and for a short period of time with Dielectric Communications. He is currently an Associate Member of the AFCCE and a Senior Member of IEEE. He has authored a chapter on filters and combining systems for the latest edition of the CRC Electronics Handbook and for the 9th Edition of the NAB Handbook.

EQUIPMENT:

The scale model pattern range consists of a wooden rotating pedestal equipped with a position indicator. The scale model bay is placed on the top of this pedestal and is used in the transmission mode at approximately 20 feet above ground level. The receiving corner reflector is spaced 50 feet away from the rotating pedestal at the same level above ground as the transmitting model. The transmitting and receiving signals are carried to a control building by means of RG-9/U double shielded coax cable.

The control building is equipped with:

Hewlett Packard Model 8753 Network Analyzer

PC Based Controller

Hewlett Packard 7550A Graphics Plotter

The test equipment is calibrated to ANSI/NCSS Z540-1-1994.

TEST PROCEDURES:

The corner reflector is mounted so that the horizontal and vertical azimuth patterns are measured independently by rotating the corner reflector by 90 degrees. The network analyzer was set to 409.95 MHz. Calibrated pads are used to check the linearity of the measuring system. For example, 6 dB padding yields a scale reading of 50 from an unpadding reading of 100 in voltage. From the recorded patterns, the R.M.S. values are calculated and recorded as shown in Figure 1.

Respectfully submitted by:



Robert A. Surette
Manager of RF Engineering
S/O 23097
October 21, 2003

FIGURE 1

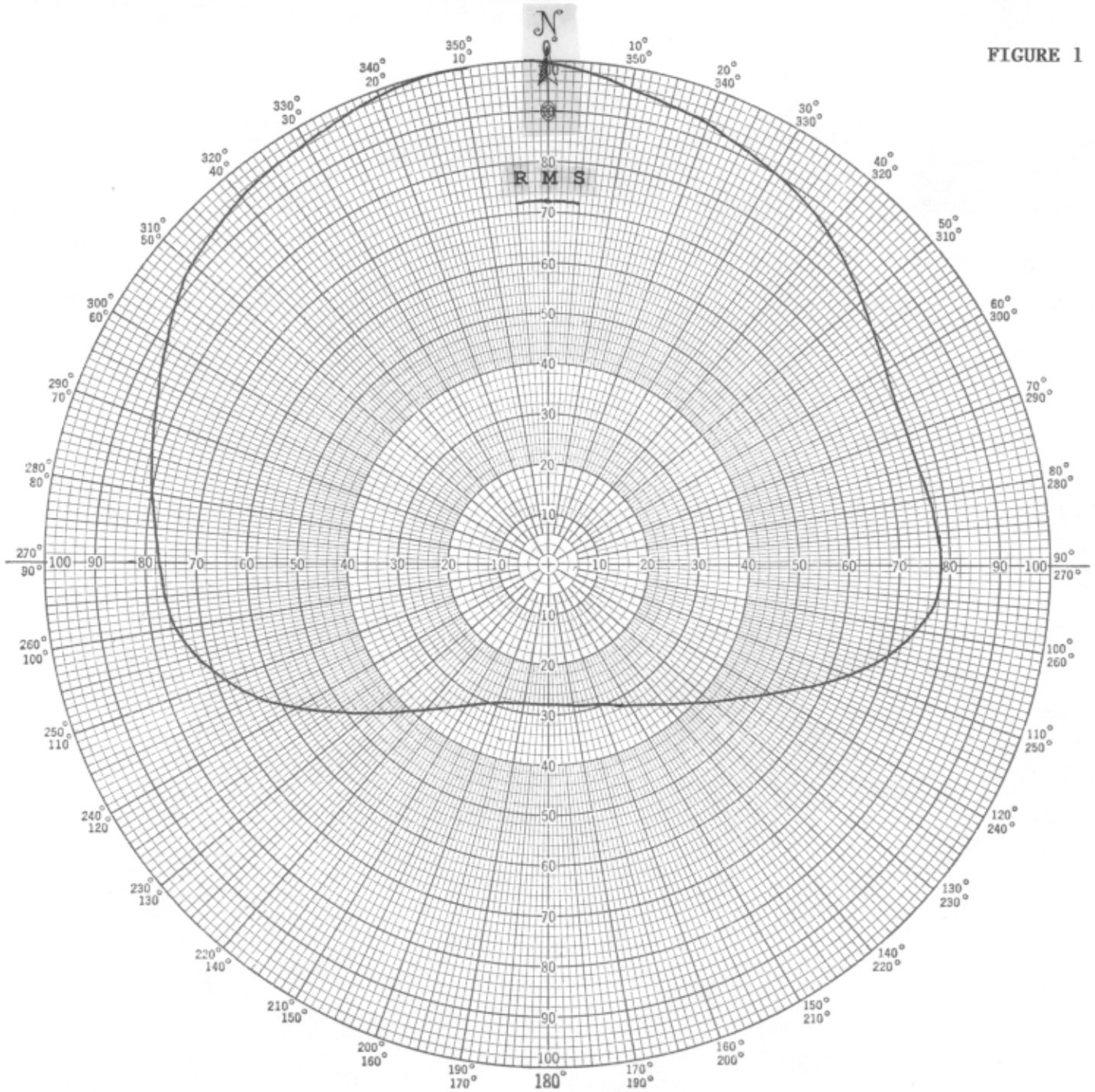

Shively Labs

PROJECT NAME KOJO LAKE CHARLES, LA
 PROJECT NUMBER 23097 DATE 10/16/03
 MODEL () FULL SCALE () FREQUENCY 409.95/91.1 MHz
 POLARIZATION VERTICAL
 CURVE PLOTTED IN: VOLTAGE () POWER () DB ()
 OBSERVER RAS

ANTENNA TYPE 6810-4-H/V-DA
 PATTERN TYPE DIRECTIONAL AZIMUTH
 REMARKS: SEE FIGURE 2 FOR MECHANICAL
 DETAILS

Figure 1A

S/O 23097
TABULATION OF VERTICAL POLARIZATION
KOJO LAKE CHARLES, LA

DEGREE	RELATIVE FIELD	DEGREE	RELATIVE FIELD
0	0.995	180	0.280
10	0.960	190	0.280
20	0.930	200	0.290
30	0.900	210	0.330
40	0.865	220	0.380
45	0.840	225	0.420
50	0.815	230	0.465
60	0.780	240	0.575
70	0.760	250	0.685
80	0.770	260	0.750
90	0.780	270	0.770
100	0.745	280	0.800
110	0.640	290	0.830
120	0.510	300	0.875
130	0.430	310	0.920
135	0.390	315	0.940
140	0.360	320	0.950
150	0.325	330	0.965
160	0.295	340	0.990
170	0.285	350	1.000

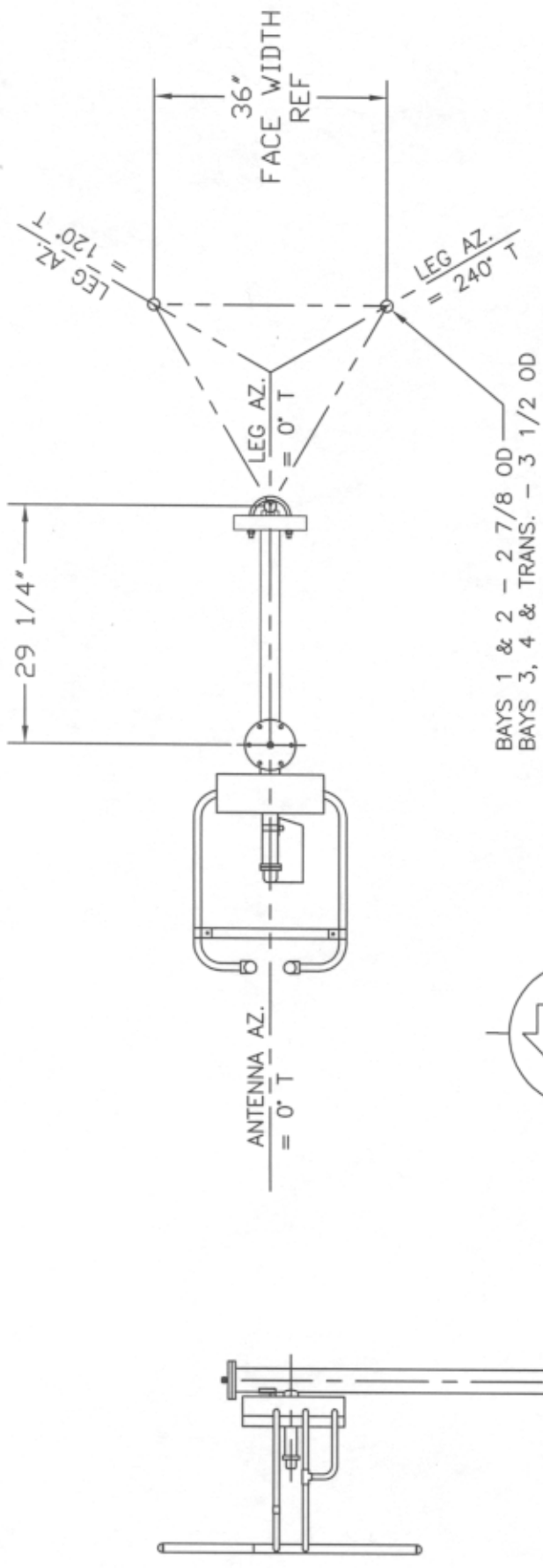

TOP VIEW

TOWER: LAROUGE-36

SIDE VIEW

SHIVELY LABS			
A DIVISION OF HOWELL LABORATORIES INC., BRIDGTON, MAINE			
SHOP ORDER: 23097	FREQUENCY: 91.1 MHz.	SCALE: N.T.S.	DRAWN BY: ASP
MODEL: 6810-4-H/V-DIRECTIONAL ANTENNA		APPROVED BY:	
DATE: 10/20/03	FIGURE 2		

Vertical Polarization - Antenna Gain

FIELD ELEVATION PATTERN

ANT. MFG.: SHIVELY LABS
ANT. TYPE: 6810-4-H/U-DA
STATION: KOJO
FREQ: 91.1 MHz CHAN: 216
Power Gain 5.270 7.218 dB
DATE: 10/15/03
FIGURE NO.: 3

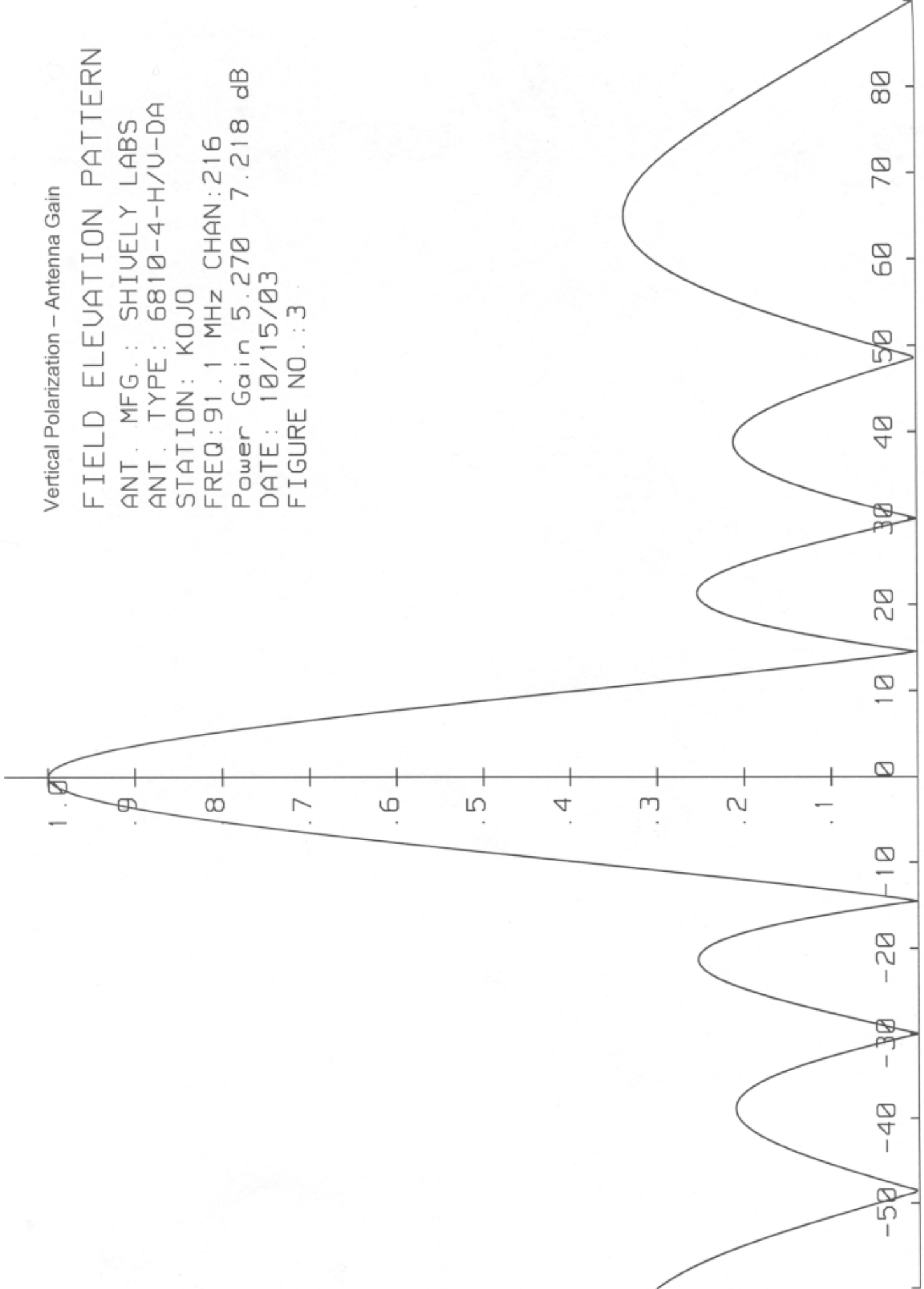

Horizontal Polarization - Antenna Gain

FIELD ELEVATION PATTERN

ANT. MFG.: SHIVELY LABS
ANT. TYPE: 6810-4-H/U-DA
STATION: KOJO
FREQ: 91.1 MHz CHAN: 216
Power Gain 1.510 1.790 dB
DATE: 10/15/03
FIGURE NO.: 3A

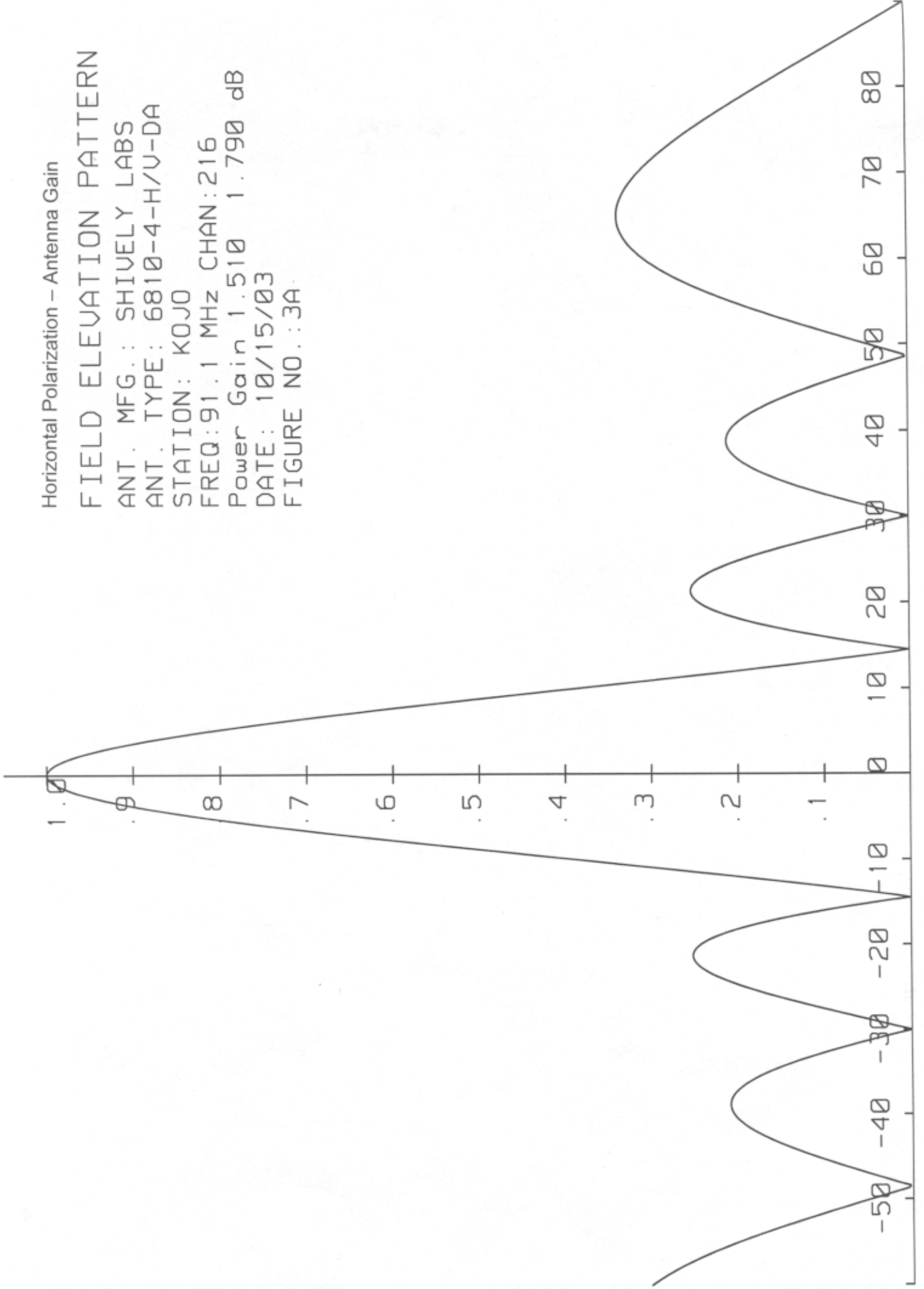

S.O. 23097

VALIDATION OF GAIN CALCULATION

KOJO LAKE CHARLES, LA

MODEL 6810-4-H/V-DA

Vertical Elevation Gain of 6810-4-H/V-DA equals $1.51H/2.73V$

The RMS values are calculated utilizing the data of a planimeter.

The H/V Ratio = $0.356H/0.644V$

Elevation Gain of Horizontal Component equals 1.51

Elevation Gain of Vertical Component equals 2.73

Vertical Azimuth Gain equals $1/(RMS)^2$
 $1/(0.72)^2 = 1.93$

- Total Horizontal Gain is Elevation Gain times Azimuth Gain = 1.51

- * Total Vertical Gain is Elevation Gain times Azimuth Gain
 $2.73 \times 1.93 = 5.27$

ERP divided by Vertical Gain equals Antenna Input Power
 $14.0 \text{ kW} \div 5.27 = 2.657 \text{ kW}$

Antenna Input Power times Vertical Gain equals Vertical ERP
 $2.657 \times 1.51 = 4.0 \text{ kW}$

FIGURE 5

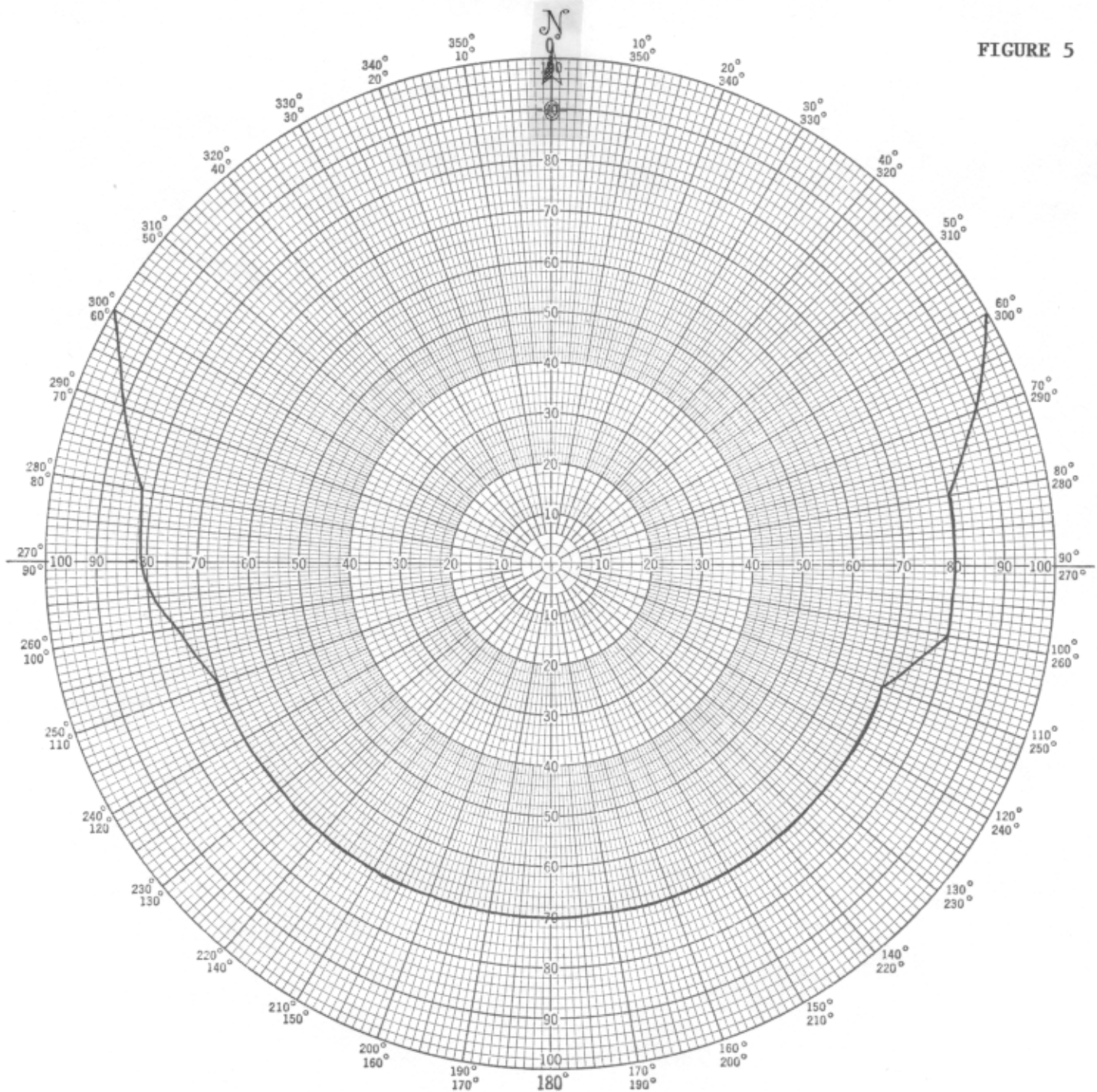

Shively Labs

PROJECT NAME KOJO LAKE CHARLES, LA
 PROJECT NUMBER 23097 DATE 10/16/03
 MODEL () FULL SCALE () FREQUENCY 409.95/91.1 MHz
 POLARIZATION COMPOSITE
 CURVE PLOTTED IN: VOLTAGE () POWER () DB ()
 OBSERVER RAS

ANTENNA TYPE 6810-4-H/V-DA
 PATTERN TYPE DIRECTIONAL AZIMUTH
 REMARKS: _____

Figure 5A

S/O 23097
TABULATION OF COMPOSITE POLARIZATION
KOJO LAKE CHARLES, LA

DEGREE	RELATIVE FIELD	DEGREE	RELATIVE FIELD
0	1.000	180	0.700
10	1.000	190	0.700
20	1.000	200	0.700
30	1.000	210	0.700
40	1.000	220	0.700
45	1.000	225	0.700
50	1.000	230	0.700
60	1.000	240	0.700
70	0.900	250	0.700
80	0.800	260	0.750
90	0.800	270	0.810
100	0.800	280	0.820
110	0.700	290	0.900
120	0.700	300	1.000
130	0.700	310	1.000
135	0.700	315	1.000
140	0.700	320	1.000
150	0.700	330	1.000
160	0.700	340	1.000
170	0.700	350	1.000